

CLAMPBROS®

STRONG-ARM

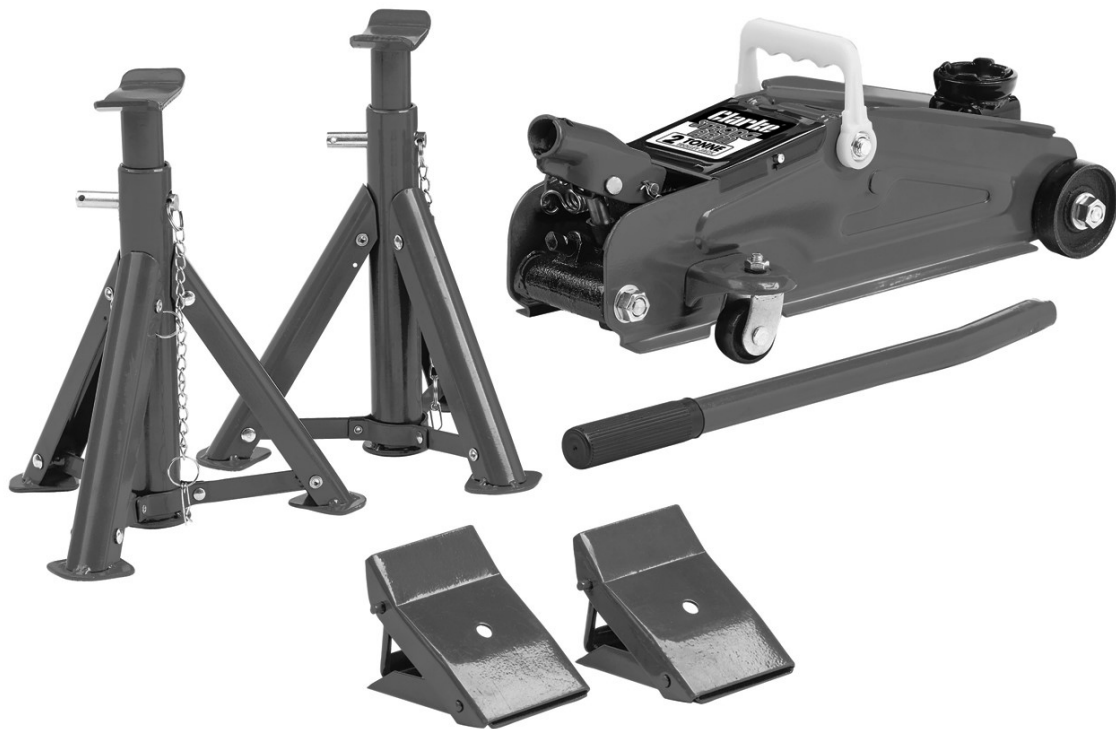

5 PIECE LIFTING KIT

MODEL NO: CGLK1

PART NO: 7623300

OPERATION & MAINTENANCE INSTRUCTIONS



ORIGINAL INSTRUCTIONS

DL0122 - Iss 2

INTRODUCTION

Thank you for purchasing this CLARKE Lifting Kit.

Before attempting to use this product, please read this manual thoroughly and follow the instructions carefully. In doing so you will ensure the safety of yourself and that of others around you, and you can look forward to your purchase giving you long and satisfactory service.

The CGLK1 Lifting Kit consists of the following items;

- Trolley jack c/w handle
- Pair folding axle stands
- Pair Wheel chocks
- Blow-moulded carrying case

GUARANTEE

These products are guaranteed against faulty manufacture for a period of 12 months from the date of purchase. Please keep your receipt which will be required as proof of purchase.

This guarantee is invalid if the product is found to have been abused or tampered with in any way, or not used for the purpose for which it was intended.

Faulty goods should be returned to their place of purchase, no product can be returned to us without prior permission.

This guarantee does not effect your statutory rights.

THE TROLLEY JACK

TECHNICAL SPECIFICATION

Length (exc handle):	447 mm
Width:	196 mm
Min height of lifting cup:	135 mm
Maximum lifting height from floor:	340 mm
Distance raised per stroke	5.3 mm
Number of strokes to maximum height	38
Weight:	8.7 kg
Pump Oil Capacity:	90 ml
Rated Capacity:	2 Tonnes

SAFETY PRECAUTIONS



WARNING: THE USER MUST FOLLOW ALL INSTRUCTIONS WITHIN THIS INSTRUCTION BOOKLET.

1. The jack is for lifting only. **DO NOT** move a load using the jack as a dolly.
2. **DO NOT** use the jack to lift people.
3. Always inspect the jack and stands before use. Make sure that all parts are in good condition and operating smoothly and that no cracks or distortion is apparent. If in doubt do not use. Have the damaged parts replaced or consult your CLARKE dealer.
4. **Make sure that the jack and stands are on a firm level base and there is no possibility of items slipping when under load.**
5. Make sure the load is taken by the full saddle and that the point of lift on the load, is strong enough to support the load adequately.

6. **DO NOT work under the raised vehicle until it is supported by suitable means e.g. axle stands, NEVER rely on the jack to support the vehicle by itself.**
7. Never push a load off the jack or stands.
8. Ensure that all personnel are well clear of a load being raised or lowered.
9. DO NOT try to lift more than the rated load for the jack.
10. DO NOT use the jack if an oil leak is apparent. Consult your CLARKE dealer.
11. Consult the vehicle handbook to determine the correct lifting points.
12. Always watch the jack and the load during operation.
13. Check the condition of the labels regularly and replace as required.
14. The jack must be maintained and repaired by suitably qualified persons.
15. DO NOT make any modifications to the jack or adjust any valves.

BEFORE USE

1. Before use, attach the lifting handle by clipping it over the two large nuts at the main arm pivot.
2. Inspect the jack for oil leaks or any sign of damage. If in doubt, do not use. Should any defects be apparent, have the jack repaired by your CLARKE dealer.
3. Check the piston for dirt, rust etc which can damage the piston and internal components.

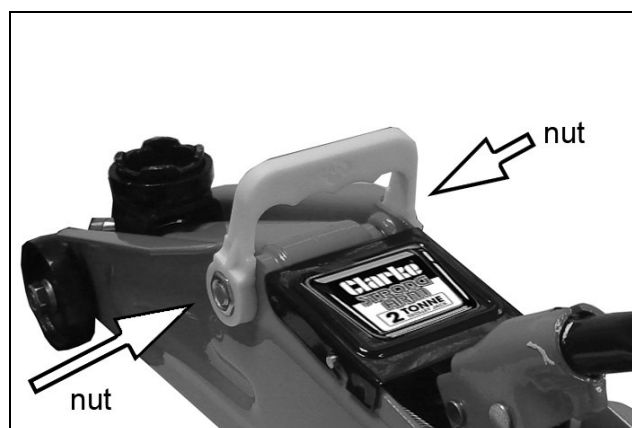

The jack is now ready to use.

USING THE TROLLEY JACK



WARNING: NEVER WORK ON THE VEHICLE WHEN SUPPORTED ONLY BY A JACK. THIS IS HIGHLY DANGEROUS. THE VEHICLE MUST BE SUPPORTED ON AXLE STANDS OR SUITABLE SUPPORTS BENEATH THE CORRECT JACKING/SUPPORT POINTS.

1. Ensure the vehicle to be raised is stable and on firm level ground with the wheels chocked with the chocks supplied.

NOTE: The jack may move slightly as the load is raised. It is important therefore, that the floor is clean and completely free from debris.

2. Position the jack so that the saddle is directly beneath the lifting point.
 - Consult the vehicle handbook to determine the lifting points.
3. Place the operating lever over the release valve and turn it fully clockwise to close the valve.
4. Place the operating lever in the jacking port and pump the operating lever so that the saddle rises to the lifting point.

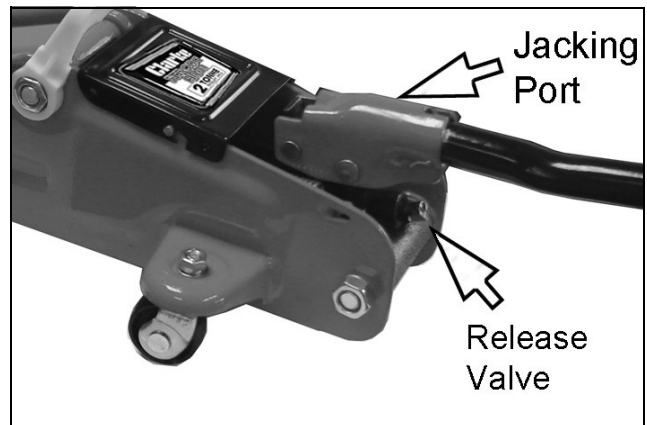

Check that there are no obstacles to prevent a clean lift, also, make sure that all personnel are well away from the area, before raising the vehicle.

5. Pump the handle to raise the vehicle to the required level.
 - If, at any time, the jack feels spongy, follow the bleeding procedure under Maintenance.
6. Position the axle stands directly beneath the supporting points on the vehicle and perfectly stable before full weight is taken. Place the operating lever over the release valve and very gently twist the operating lever anti-clockwise to lower the load onto the stands.
7. Check constantly, preferably with an assistant, that the vehicle is resting correctly on the axle stands and that the stands are stable before the weight is taken.
8. To stop it lowering at any point, turn the operating lever clockwise again. Always avoid a rapid descent by turning the operating lever slowly.

NOTE: Ensure this is carried out under complete control. DO NOT allow the load to drop suddenly as this could damage internal parts.

9. Completely remove the jack from the vehicle.

MAINTENANCE

CHECKING/MAINTAINING THE OIL LEVEL

1. Ensure the jack is fully lowered by turning the control valve fully anti-clockwise.
2. Remove the filler plug.
 - The oil should be almost level with the bottom of the filler hole
 - Oil can be topped up using CLARKE Hydraulic Oil (p/n 3050830 1 litre).

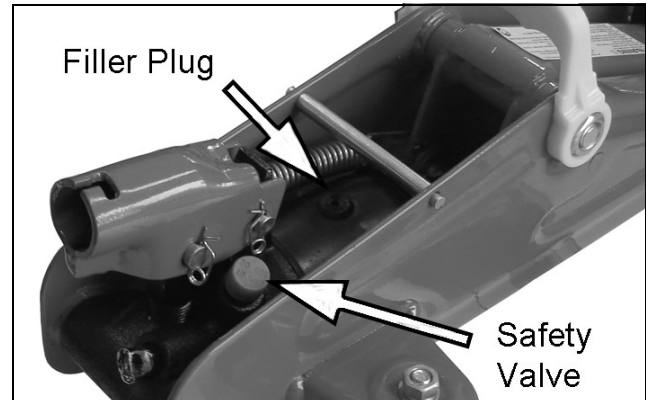

3. Bleed any air from the jack as described below and replace the filler plug and cover plate.

Dispose of old/spilled oil appropriately and wipe up any spillage.

BLEEDING AIR FROM THE SYSTEM

1. Use the operating lever to turn the release valve anti-clockwise, relieving pressure inside the jack.
2. Pump the operating lever several times to purge air from the jack.
3. Turn the release valve clockwise and test the jack. If efficiency is still low, check the oil level as described above.

STORAGE

1. Store in the blow-moulded case with the ram fully retracted, where it cannot be damaged by moisture. If stored for long periods, clean any grime from the piston area before use.

ENVIRONMENTAL PROTECTION

One of the most damaging sources of environmental pollution is oil products. Never throw away used hydraulic oil with domestic refuse or flush it down a sink or drain. Collect any hydraulic oil in a leak proof container and take it to your local waste disposal site.

If disposing of this product or any damaged components, do not dispose of with general waste. This product contains valuable raw materials and should be taken to your local civic amenity site for recycling of metal products.

TROUBLESHOOTING

PROBLEM	CAUSE	SOLUTION
Jack will not lift the rated load	Low oil level	Check for leakage and top up if required.
	Release valve not closed	Turn release knob fully clockwise
	Air in the hydraulic ram	Bleed air as on page 6.
Jack lowers when under load	Release valve not fully closed	Turn the release knob fully clockwise
	Air in the hydraulic ram	Bleed air as on page 6.
Pump feels spongy	Low oil level	Check for leakage and top up if required.
	Air in the system	Bleed air as on page 6.
Handle raises or flies back under load	Air in the hydraulic ram	Bleed air as on page 6.
Jack will not lift full height	Low oil level	Check for leakage and top up if required.
	Air in the hydraulic ram	Bleed air as on page 6.
Jack will not lower completely	Return spring may be faulty.	Return to your CLARKE dealer for repair

If any of these remedies fail to restore your jack, consult your dealer.

SPARE PARTS

The following user serviceable parts are available from your CLARKE dealer, or CLARKE International Parts Department: Carrying Handle, Operating Lever, Castor Assembly.

THE WHEEL CHOCKS

Use the wheel chocks to prevent vehicle movement when a vehicle is being jacked on a level surface or parked on an incline.

Length x width x height (open)	128 x 100 x 82 mm
Product Weight	0.34 kg

THE AXLE STANDS

Minimum Height position 1	278 mm
Minimum Height position 2	322 mm
Minimum Height position 3	366 mm
Maximum Load	2 Tonnes
Product Weight	1.6 kg
Number of Height Positions	3

SAFETY WARNINGS - ALWAYS READ BEFORE USE



WARNING: USE ONLY ON A HARD, FLAT SURFACE FOR EXAMPLE CONCRETE.

WARNING: NEVER WORK UNDER A VEHICLE SUPPORTED ONLY BY A JACK.

WARNING: AFTER LIFTING THE VEHICLE, SUPPORT IMMEDIATELY WITH PROPERLY RATED AXLE STANDS

Read these instructions carefully before use.

Do not exceed the axle stands maximum load. The vehicle weight will be in the owners manual.

Use only as specified in this manual.

NEVER let children play in or around a vehicle that is on axle stands.

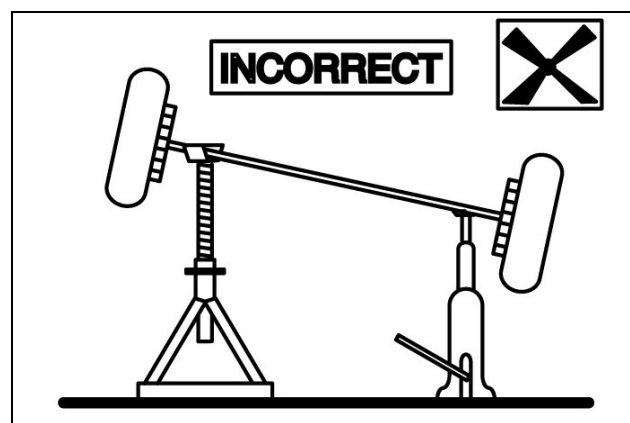

ALWAYS make sure that before you work below the vehicle, a responsible person is aware in case of injury or accident.

Do not use more than one pair of axle stands.

Replace the warning label if it becomes unreadable.

Use only on a hard, flat surface such as concrete.

Make sure that you chock all the wheels that remain on the ground.

Make sure that the supported vehicle cannot move.

Set each axle stand below an appropriate point on the vehicle - See your vehicle owners manual for advice.

Take care when using the axle stands under a three-wheeled vehicle or trailer.

Upper and lower columns are to be used as a pair as supplied.

Use stands as a matched pair to support one end of a vehicle only.

For your safety, do not modify these axle stands in any way.

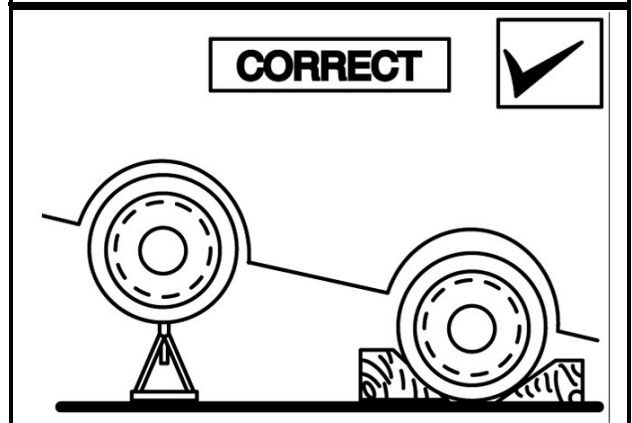
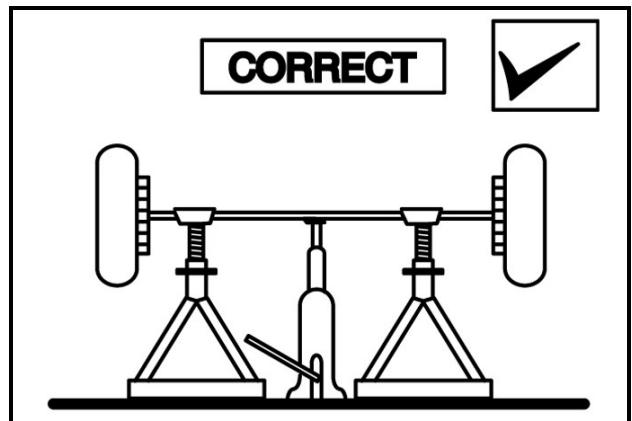
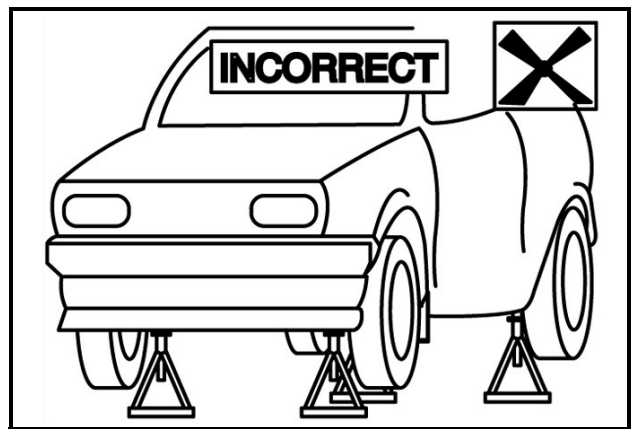

USING THE AXLE STANDS



WARNING: BEFORE USE, MAKE SURE THAT THERE IS NO DAMAGE TO ANY PART OF THE AXLE STAND. IF ANY FOUND, DO NOT USE.

WARNING: ENSURE THAT THE VEHICLE/LOAD IS CAREFULLY LOCATED ON THE CENTRE OF THE SADDLE. FAILURE TO DO THIS CAN RESULT IN DAMAGE TO THE AXLE STANDS, LOSS OF SUPPORT TO THE LOAD, SERIOUS PERSONAL INJURY OR LOSS OF LIFE.

1. Refer to the vehicle handbook for the correct jacking procedure and location of the support points.
2. Fully spread the three legs.

ADJUST THE AXLE STAND

1. Remove the locating pin (if fitted).
2. Raise the upper column to the required height and fit the locating pin into the lowest hole visible.
3. Insert the retaining pin into the end of the locating pin to secure it.
4. Position the axle stand under a suitable supporting point. See your vehicle manual for the location.

LOWERING THE VEHICLE

1. Slowly lower the vehicle onto the centre of the saddle.

REMOVING THE AXLE STANDS

1. Raise the vehicle and remove the stands. Ensure that all tools, equipment and personnel are clear before carefully lowering the vehicle to the ground.

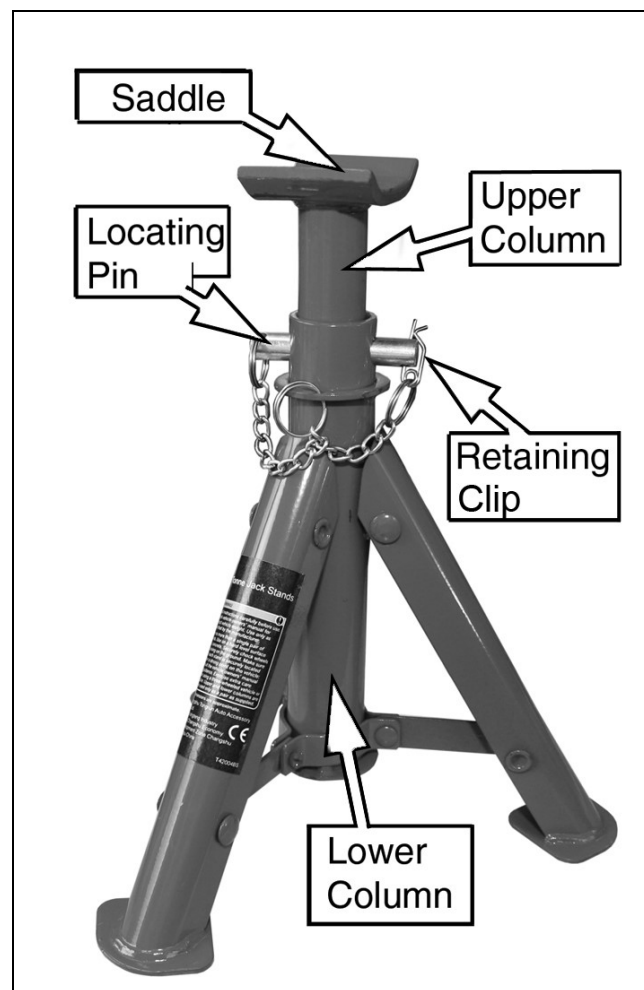

DECLARATION OF CONFORMITY



DECLARATION OF CONFORMITY

This is an important document and should be retained.

We hereby declare that this product(s) complies with the following statutory requirement(s):
Supply of Machinery (Safety) Regulations 2008

The following standards have been applied to the product(s):
EN 1494:2000+A1:2008.

The technical documentation required to demonstrate that the product(s) meet(s) the requirement(s) of the aforementioned legislation has been compiled and is available for inspection by the relevant enforcement authorities.

The UKCA mark was first applied in: 2021

Product Description: 2 Tonne Jack + Axle Stands and Wheel Chocks
Model number(s): CGLK1
Serial / batch Number: N/A
Date of issue: 11/01/2022

Signed:

J.A. Clarke
Director



DECLARATION OF CONFORMITY

This is an important document and should be retained.

We hereby declare that this product(s) complies with the following directive(s):
2006/42/EC Machinery Directive.

The following standards have been applied to the product(s):
EN 1494:2000+A1:2008.

The technical documentation required to demonstrate that the product(s) meet(s) the requirement(s) of the aforementioned directive(s) has been compiled and is available for inspection by the relevant enforcement authorities.

The CE mark was first applied in: 2020

Product Description: 2 Tonne Jack + Axle Stands and Wheel Chocks
Model number(s): CGLK1
Serial / batch Number: N/A
Date of issue: 11/01/2022

Signed:

J.A. Clarke
Director

A SELECTION FROM THE VAST RANGE OF

Clarke®

QUALITY PRODUCTS



AIR COMPRESSORS
From DIY to industrial, Plus air tools,
spray guns and accessories.

GENERATORS
Prime duty or emergency standby
for business, home and leisure.

POWER WASHERS
Hot and cold, electric and engine
driven - we have what you need

WELDERS
Mig, Arc, Tig and Spot.
From DIY to auto/industrial.

METALWORKING
Drills, grinders and saws for DIY
and professional use.

WOODWORKING
Saws, sanders, lathes, mortisers
and dust extraction.

HYDRAULICS
Cranes, body repair kits,
transmission jacks for all types of
workshop use.

WATER PUMPS
Submersible, electric and engine driven
for DIY, agriculture and industry.

POWERTOOLS
Angle grinders, cordless drill sets,
saws and sanders.

STARTERS/CHARGERS
All sizes for car and commercial use.



PARTS & SERVICE: 0208 988 7400

Parts Enquiries
Parts@clarkeinternational.com

Servicing & Technical Enquiries
Service@clarkeinternational.com

SALES: UK 01992 565333 or Export 00 44 (0)1992 565335

Clarke® INTERNATIONAL Hemnall Street, Epping, Essex CM16 4LG
www.clarkeinternational.com